

PATENT PENDING

**IKO**

**Maintenance Free**

# *C-Lube Bearing*

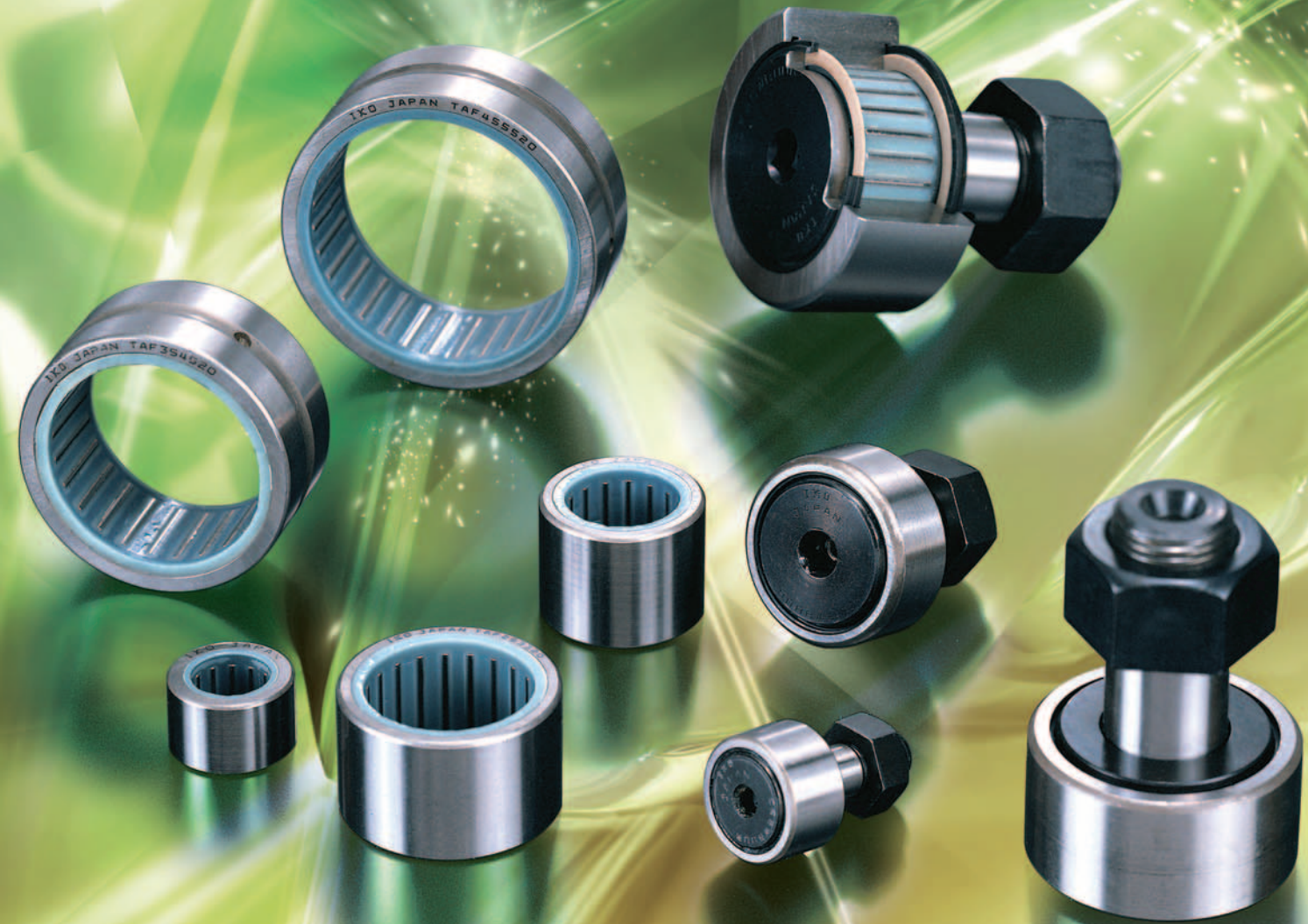

CAT-57165

# Environment-friendly **IKO** C-Lube Bearings Minimizing Lubricant Requirement

## What is your trouble?

- 1 *Hard access to lubricating?*
- 2 *Machines and work places are dirty with lubricant?*
- 3 *Lubricating tools and instruments occupy the working places?*
- 4 *Having problems keeping up with lubrication maintenance schedule?*

## Find solutions with **IKO**

"C-Lube bearings" are **IKO**'s unique maintenance free bearing products with thermosetting solid lubricant (Capilube) pre-packed in the bearing space. As the bearing rotates, the lubricating oil oozes out onto needle rollers and raceways in proper quantity keeping the lubrication performance for a long period of time.

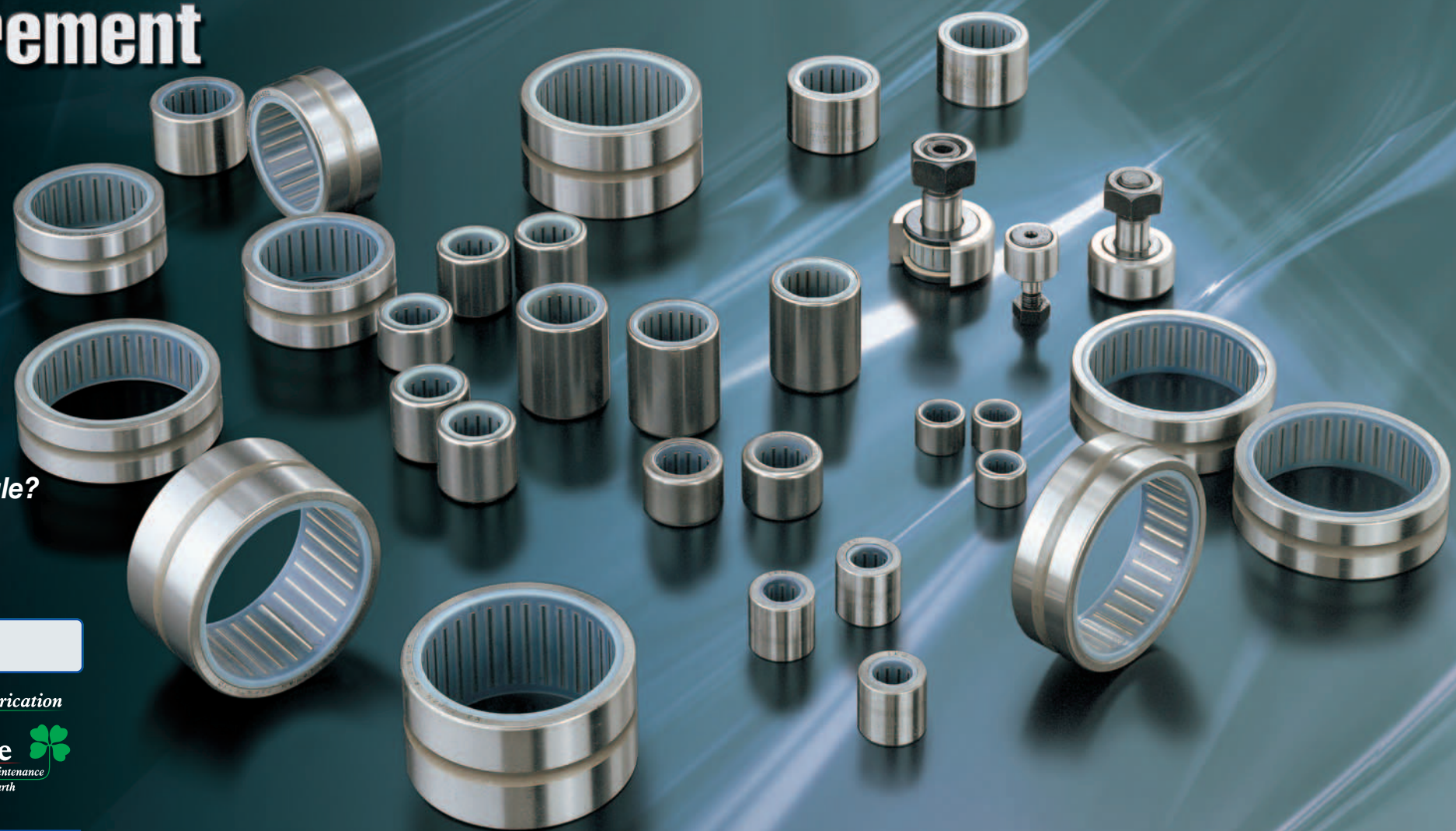

### For shaft support

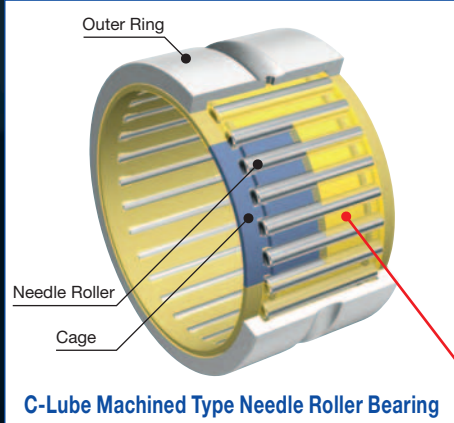

### For cam mechanisms and follower bearings

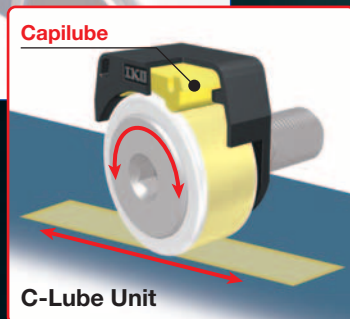
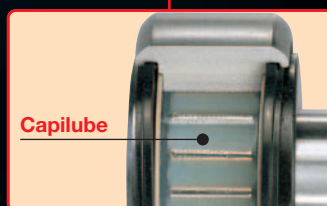
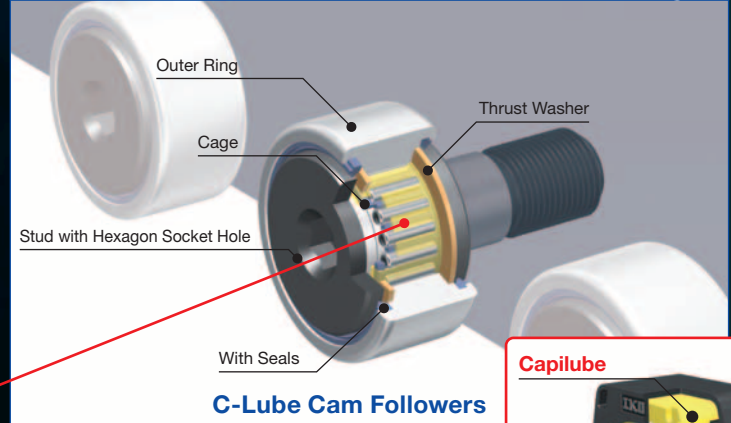

**Maintenance work can be reduced greatly**

**Minimizes the amount of lubricant and contributes to the earth environment**

**Suppresses machine designing and device costs**

*Requires no periodical lubrication and increases the productivity.*

*Contributes to the earth environment and reduces the running cost.*

*Working spaces can be utilized.*

# C-Lube Machined Type Needle Roller Bearings TAF.../SG



C-Lube Machined Type Needle Roller Bearing

IKO C-Lube Machined type Needle Roller bearing is a maintenance free type product made by pre-packed thermosetting solid lubricant (Capilube) in Machined type Needle Roller Bearing. This needle bearing features low sectional height, great load rating, and stable outer ring rigidity.

**Maintenance free Compact Great load rating**

## Excellent performance

### Rotational endurance test

● Test conditions  
 Test bearing : TAF45520/SG Rotational speed : 400 rpm  
 Load amount : 3000N Ambient temperature : Room temperature

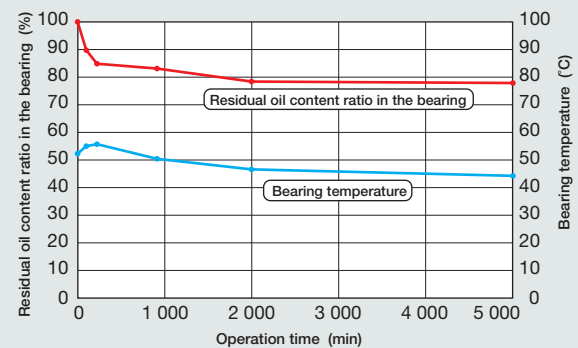

### Oscillating endurance test

● Test conditions  
 Test bearing : TAF253316/SG Oscillating speed : 217 cpm  
 Load amount : 1960N Ambient temperature : Room temperature  
 Oscillating angle :  $2\theta=151^\circ$

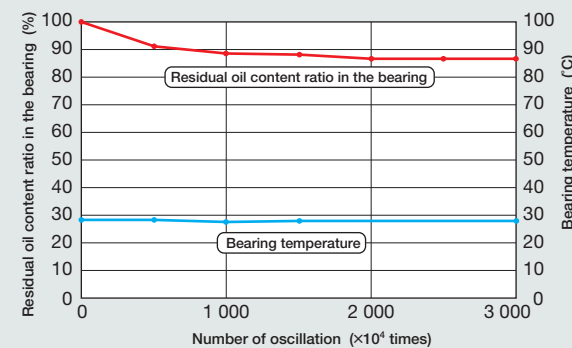

## Variations

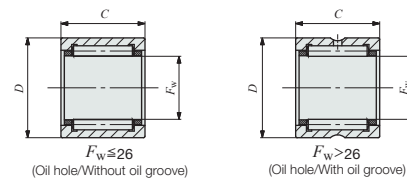

### Major applications

- Printing machines
- Textile machines
- Machine tools

Identification number	Bearing bore diameter $F_w$	Bearing outside diameter $D$	Width $C$
TAF 121912/SG	12	19	12
TAF 121916/SG			16
TAF 152316/SG	15	23	16
TAF 152320/SG			20
TAF 182616/SG	18	26	16
TAF 182620/SG			20
TAF 202816/SG	20	28	16
TAF 202820/SG			20

Identification number	Bearing bore diameter $F_w$	Bearing outside diameter $D$	Width $C$
TAF 223016/SG	22	30	16
TAF 223020/SG			20
TAF 253316/SG	25	33	16
TAF 253320/SG			20
TAF 304020/SG	30	40	20
TAF 304030/SG			30
TAF 455520/SG	45	55	20
TAF 455530/SG			30

# C-Lube Cam Followers CF.../SG C-Lube Unit CL



C-Lube Cam Follower



C-Lube Unit

IKO C-Lube Cam Follower is a maintenance free type Cam Follower made by pre-packing a thermosetting solid lubricant "Capilube" in Cam Follower with Thrust Washers.

This is a follower bearing with shaft stud that houses needle rollers in a thick outer ring and used for cam mechanisms and linear motion guides.

C-Lube Unit for a cam follower is an IKO original lubrication part to be mounted on a cam follower. C-Lube Unit supplies lubricant oil to the outer surface of the cam follower and the opposite guide surface and realize a maintenance free cam guide.

**Maintenance free Easy mounting structure IKO original**

## Excellent performance

### Rotational endurance test

● Test conditions  
 Test bearing : CF10WBUUR/SG  
 Rotational speed : 1000 rpm  
 Ambient temperature : Room temperature

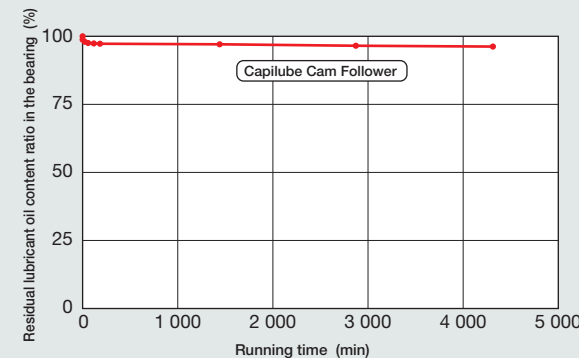

### Endurance test

● Test conditions (1)  
 Sample : CL12 Stroke length : 300 mm  
 CF12WBUUR/SG Specification of raceway surface : Material SKD11  
 Lubricating condition : Capilube unit only, without grease pre-packed : Hardness HRC58 or more  
 Maximum speed : 2000 mm/s Ambient temperature : Room temperature

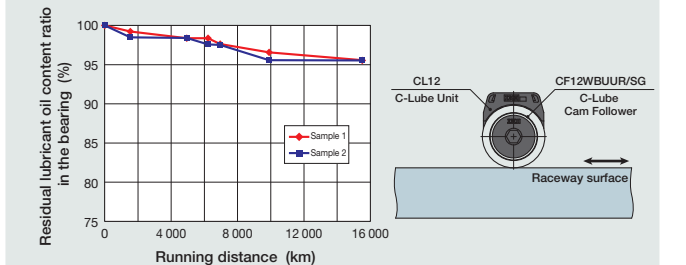

Note (1) The test raceway was ground for confirmation of endurance. When the other conditions are used, please confirm it in the actual customer conditions.

## Variations

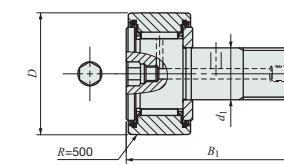

### Major applications

- Machine tools
- Sliding doors
- Transporting equipment

Identification number	Stud diameter $d_1$	Outer ring diameter $D$	Length $B_1$	Applied Capilube unit
CF 6 WBUUR/SG	6	16	28.2	CL 6
CF 8 WBUUR/SG	8	19	32.2	CL 8
CF 10 WBUUR/SG	10	22	36.2	CL 10
CF 10-1 WBUUR/SG	10	26	36.2	CL 10-1
CF 12 WBUUR/SG	12	30	40.2	CL 12
CF 12-1 WBUUR/SG	12	32	40.2	CL 12-1
<b>NEW</b> CF 16 WBUUR/SG	16	35	52.1	—
CF 18 WBUUR/SG	18	40	58.1	—
CF 20 WBUUR/SG	20	52	66.1	—
CF 20-1 WBUUR/SG	20	47	66.1	—

## Identification number

• Example

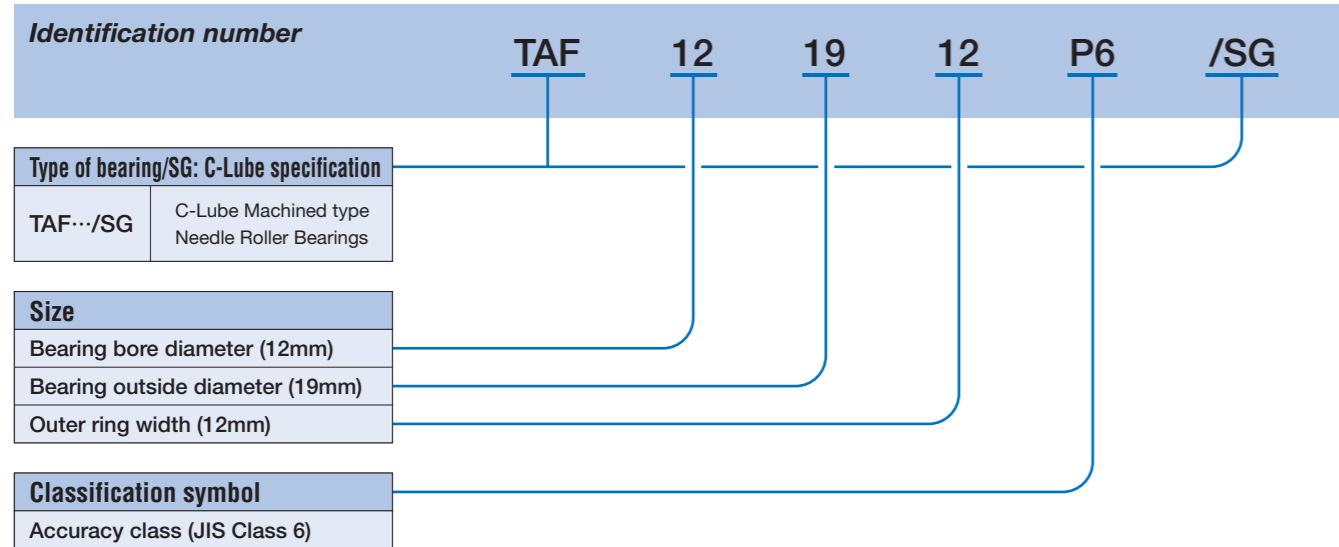

## Basic dynamic load rating

The basic dynamic load rating is defined as the constant radial load acting along the bearing central axis that allows a basic rating life of 1,000,000 revolutions.

## Basic static load rating

The basic static load rating is the static load that gives the contact stress reaches 4,000Mpa at the center of the contact area of the rolling elements and the raceway receiving the maximum load.

## Accuracy

The accuracy of IISO C-Lube Machined type Needle Roller Bearings conforms to JIS B 1514-1~3:2006 (Tolerances of Rolling Bearings), and the dimensional accuracy and rotational accuracy are specified. Representative tolerances of outer ring are shown in Table 1 and the tolerances for the smallest single roller set bore diameter is shown in Table 2.

Table 1 Tolerance for outer ring unit :  $\mu\text{m}$

D Nominal bearing outside diameter mm	$\Delta D_{mp}$ Single plane mean outside diameter deviation								$\Delta C_s$ Deviation of a single outer ring width								
	Class 0		Class 6		Class 5		Class 4		Class 0		Class 6		Class 5		Class 4		
	High	Low	High	Low	High	Low	High	Low	High	Low	High	Low	High	Low	High	Low	
18	22	0	-9	0	-8	0	-6	0	-5	0	-120	0	-120	0	-40	0	-40
22	30	0	-9	0	-8	0	-6	0	-5	0	-120	0	-120	0	-80	0	-80
30	50	0	-11	0	-9	0	-7	0	-6	0	-120	0	-120	0	-120	0	-120
50	80	0	-13	0	-11	0	-9	0	-7	0	-120	0	-120	0	-120	0	-120

Table 2 Tolerances for the smallest single roller set bore diameter  $F_{ws \min}^{(1)}$

$F_w$ Nominal roller set bore diameter mm		$\Delta F_{ws \min}$ Deviation of the smallest single roller set bore diameter $\mu\text{m}$	
Over	Incl.	High	Low
10	18	+27	+16
18	30	+33	+20
30	45	+41	+25

Note (1): This is the diameter of the cylinder used instead of the inner ring, where the radial clearance becomes zero at least in one radial direction.

## Design of shaft and housing

IISO C-Lube Machined type Needle Roller Bearings do not have inner ring so that the shaft can be used directly as the raceway surfaces. For shafts and housings specification in Table 3 are recommended.

Table 3 Specification of shaft and housing

Item	Shaft	Housing
Roundness	0.3 $\times$ IT6 <sup>(1)</sup> or 0.3 $\times$ IT5 <sup>(1)</sup>	0.3 $\times$ IT7 <sup>(1)</sup> or 0.3 $\times$ IT6 <sup>(1)</sup>
Cylindricity	0.3 $\times$ IT6 <sup>(1)</sup> or 0.3 $\times$ IT5 <sup>(1)</sup>	0.5 $\times$ IT7 <sup>(2)</sup> or 0.5 $\times$ IT6 <sup>(2)</sup>
Surface roughness	0.2 $\mu\text{m}R_a$ <sup>(3)</sup>	1.6 $\mu\text{m}R_a$
Hardness	58~64HRC <sup>(4)</sup>	—

Note (1): 30% or less of the dimensional tolerance for the shafts or housing bores is recommended.  
 (2): 50% or less of the dimensional tolerance for shafts or housing bores is recommended.  
 (3): When required accuracy is not critical, a surface roughness within 0.8  $\mu\text{m}R_a$  (3.2  $\mu\text{m}R_v$ ) is allowable.  
 (4): An appropriate depth of the hardened layer is required.

## Fit

Recommended fits for IISO C-Lube Machined type Needle Roller Bearings are shown in Table 4 to 5.

Table 4 Fit between IISO C-Lube Machined type Needle Roller Bearings and housings

Load condition	Tolerance class of housing	
	Rotating load on outer ring	Normal load
Directionally indeterminate load	Light load, Fluctuating load	M 7
	Normal load	K 7
Stationary load on outer ring	Light load, normal load	J 7
	With heat conduction through shaft	H 7
With light or normal load, especially accurate rotation and high rigidity are required.		G 7
		K 6

Note (1): Be careful not to make radial internal clearance to be too small.  
 Remark 1: This table applies to steel or cast iron housings. For lighter metal, a tighter fit should be selected. For split housings, do not use a fit tighter than J7.  
 2: Light load and normal load represent  $P \leq 0.06C$  and  $0.06C < P \leq 0.12C$ , respectively, where  $P$  is the dynamic equivalent radial load and  $C$  is the basic dynamic load rating of the bearing to be used.

Table 5 Tolerance of the shafts

Radial internal clearance	Tolerance class of shaft
Smaller than CN clearance	k 5
CN clearance	h 5
Larger than CN clearance	g 6

Remark: When the housing bore fit is tighter than K7, the shaft diameter is made smaller by considering shrinkage of roller set bore diameter after mounting.

## Allowable rotational speed

The allowable rotational speeds of IISO C-Lube Machined type Needle Roller Bearings are affected by mounting and operating conditions. Recommended  $d_{m,n}$  value<sup>(1)</sup> is less than 20,000 under pure radial load condition. Under actual usage,  $d_{m,n}$  value is recommended to be less than 2,000 due to unexpected axial load.

Note (1): Value  $d_{m,n} = (\text{Bearing bore dia. [mm]} + \text{Bearing outside dia. [mm]}) / 2 \times \text{Number of revolution [rpm]}$

## Mounting

- 1 Mounting dimensions for IISO C-Lube Machined type Needle Roller Bearings are shown in the dimension table.
- 2 When mounting IISO C-Lube Machined type Needle Roller Bearings, pay attention to avoid locating the oil hole of the inner ring within the loading zone. This may lead to a short bearing life.

## Matched set bearings

When using two or more C-Lube Machined Type Needle Roller Bearings adjacent to each other on the same shaft, consult IISO.

## Caution in use

- 1 Never wash bearing with organic solvent and/or white kerosene, which have the ability to remove fat.
- 2 To ensure normal rotation of the bearing, apply a load of 1% or more of the dynamic load rating at use.
- 3 The operating temperature range is -15 to +80°C. For continuous operation, the recommended operating temperature is +60°C or less.
- 4 When using two or more IISO C-Lube Machined type Needle Roller Bearings adjacent to each other on the same shaft, it is necessary to obtain an even load distribution. Upon request, a set of bearings is available, in which bearings are matched to obtain an even load distribution.

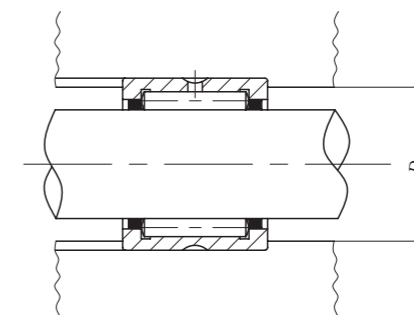
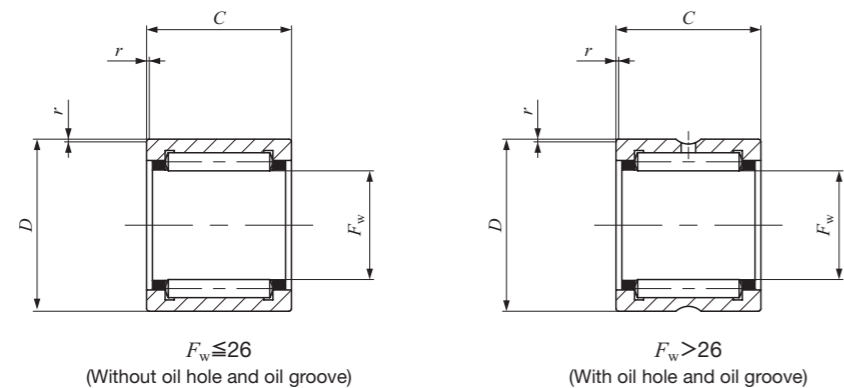

Shaft dia. mm	Identification number	Mass (Reference) g	Boundary dimensions mm		
			$F_w$	$D$	$C$
12	TAF 121912/SG	12.5	12	19	12
	TAF 121916/SG	16.8	12	19	16
15	TAF 152316/SG	23.5	15	23	16
	TAF 152320/SG	29	15	23	20
18	TAF 182616/SG	26.5	18	26	16
	TAF 182620/SG	33	18	26	20
20	TAF 202816/SG	28.5	20	28	16
	TAF 202820/SG	37	20	28	20
22	TAF 223016/SG	31	22	30	16
	TAF 223020/SG	39	22	30	20
25	TAF 253316/SG	35	25	33	16
	TAF 253320/SG	43.5	25	33	20
30	TAF 304020/SG	67	30	40	20
	TAF 304030/SG	101	30	40	30
45	TAF 455520/SG	95.5	45	55	20
	TAF 455530/SG	144	45	55	30

Note (1): Minimum allowable value of chamfer dimension  $r$ .  
 Remark: Bearing with a roller set bore diameter  $F_w$  of 26mm or less have no oil hole or oil groove. In others, the outer ring has an oil hole and an oil groove.

$r_{s\min}^{(1)}$	Standard mounting dimension $D_a$ Max. mm	Basic dynamic load rating	Basic static load rating
		$C$ N	$C_0$ N
0.3	17	6 610	7 260
0.3	17	9 250	11 200
0.3	21	12 300	14 900
0.3	21	15 600	20 200
0.3	24	13 400	17 500
0.3	24	17 000	23 600
0.3	26	13 900	18 800
0.3	26	17 600	25 400
0.3	28	14 900	21 200
0.3	28	18 900	28 700
0.3	31	15 800	23 700
0.3	31	20 000	32 100
0.3	38	25 100	40 100
0.3	38	36 000	63 900
0.3	53	31 000	60 200
0.3	53	44 600	95 800

### Example of identification number

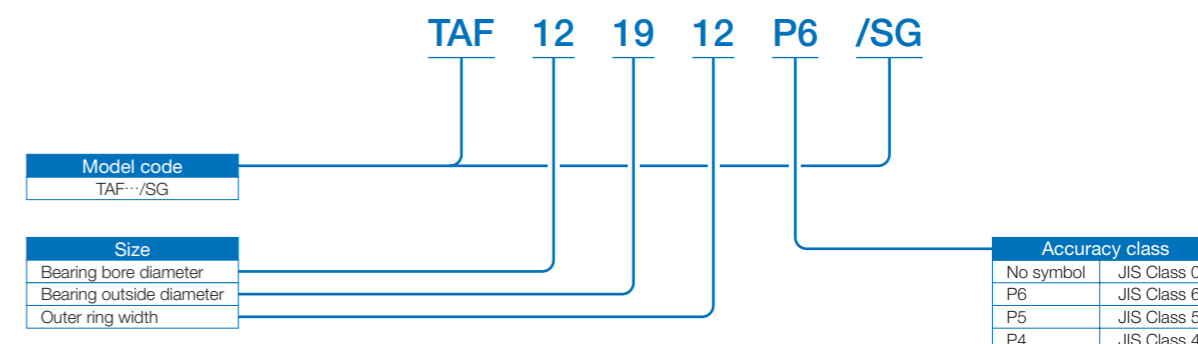

## Identification number

• Example

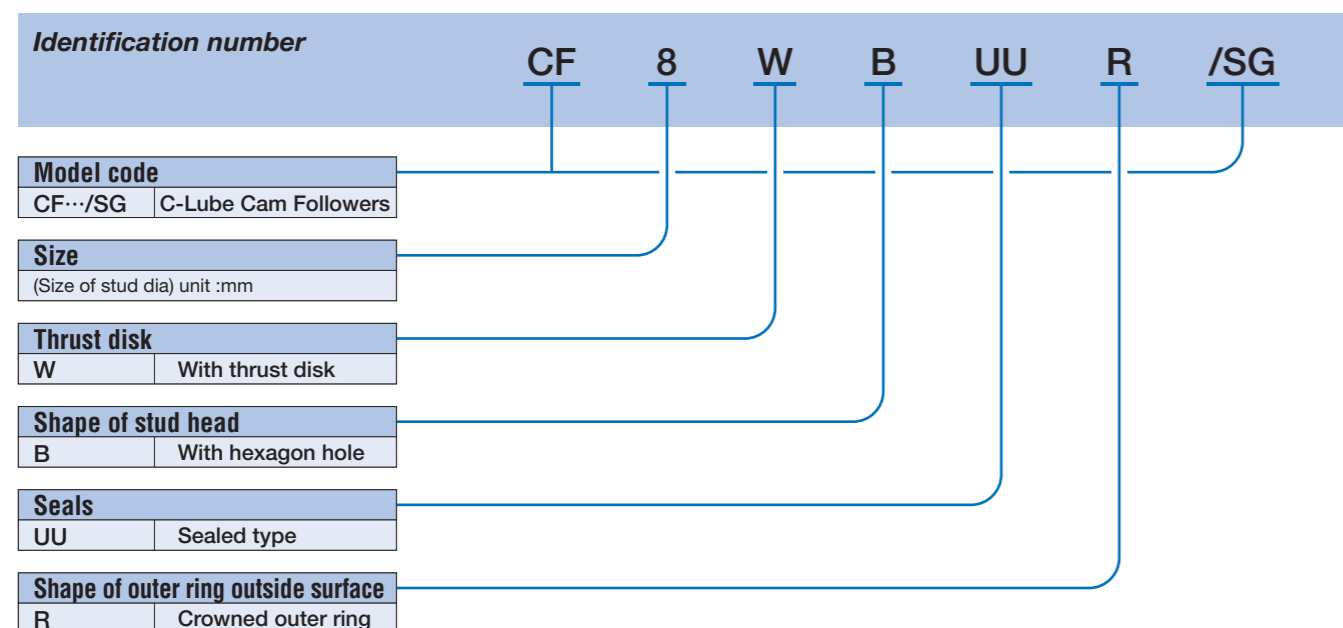

## Basic dynamic load rating

The basic dynamic load rating is defined as the constant radial load acting along the bearing central axis that allows a basic rating life of 1,000,000 revolutions.

## Basic static load rating

The basic static load rating is the static load that gives the contact stress reaches 4,000Mpa at the center of the contact area of the rolling elements and the raceway receiving the maximum load.

## Maximum Allowable Load

The applicable load on IJK C-Lube Cam Follower is, in some cases, limited by the bearing strength, shear strength of stud and the strength of outer ring instead of the load rating of needle roller bearing, because the IJK C-Lube Cam Follower to be mounted in a cantilever position. Maximum allowable loads limited by the bending strength and shear strength.

## Track capacity

The capacity is defined as the load which can be continuously applied on a IJK C-Lube Cam Follower placed on a steel track flat surface without causing deformation and indentation (dent) on the track surface.

## Accuracy

The accuracy of IJK C-Lube Cam Follower is shown in Table 6. Radial run-out of the outer ring is controlled 15μm in maximum.

**Table 6 Tolerances** unit : μm

	Outside diameter of outer ring <i>D</i>	Stud diameter <i>d<sub>1</sub></i>	Width of outer ring <i>C</i>
Tolerances	0 -50	h7	0 -120

## Clearance

The radial internal clearances of IJK C-Lube Cam Followers are shown in Table 7.

**Table 7 Radial internal clearance** unit : μm

Identification number	Radial internal clearance	
	Min	Max.
CF 6 WBUUR/SG	5	20
CF 8 WBUUR/SG	5	25
CF 10 WBUUR/SG		
CF 10-1 WBUUR/SG		
CF 12 WBUUR/SG		
CF 12-1 WBUUR/SG	10	30
CF 16 WBUUR/SG		
CF 18 WBUUR/SG		
CF 20 WBUUR/SG		
CF 20-1 WBUUR/SG		

Remark : Values are applicable before the solid type lubricant is packed.

## Fit

Mounting hole tolerance for stud is recommended to be H7 for IJK C-Lube Cam Followers. In case it is supported in a cantilever position, the mounting hole diameter should be prepared without play between the stud and the mounting hole especially when heavy shock loads are applied.

## Allowable rotational speed

The allowable rotational speeds of IJK C-Lube Cam Follower are affected by mounting and operating conditions. Recommended  $d_1n$  value<sup>(1)</sup> is less than 10,000 under pure radial load condition. Under actual usage,  $d_1n$  value is recommended to be less than 1,000 due to unexpected axial load.

Note (1):  
Value  $d_1n = d_1$  (Stud diameter [mm]) ×  $n$  (Number of revolution [rpm])

## Mounting

1 Make the center axis of the mounting hole perpendicular to the moving direction of the IJK C-Lube Cam Follower and match the side shoulder accurately with the seating surface indicated by dimension *f* in the table of dimensions. Then, fix the Cam Follower with the nut. Do not hit the flange head of the IJK C-Lube Cam Follower directly with a hammer, etc. This may lead to a bearing failures such as irregular rotation or cracking.

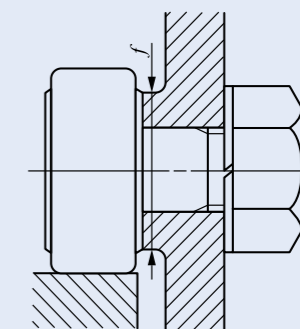

Fig.1 Seating surface

2 The IJK mark on the flange head of the stud indicates the oil hole position on the raceway. Avoid locating the oil hole within the loading zone which may lead to a short bearing life. (See Fig.2)

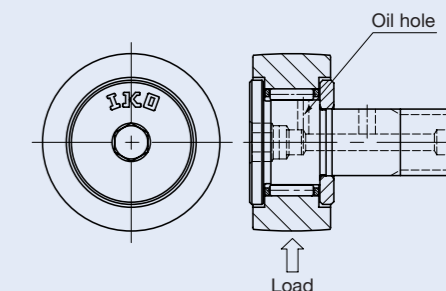
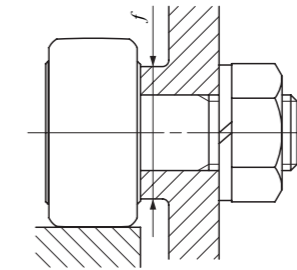
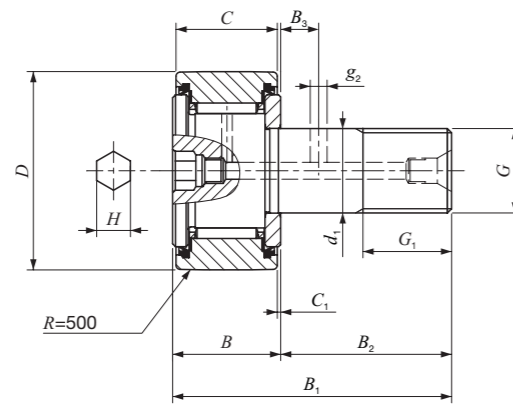

Fig.2 Oil hole position and loading direction

3 When tightening the nut, the tightening torque should not exceed the value shown in the dimension table. If the tightening torque is too large, it is possible that the threaded portion of the stud will be broken. When there is a possibility of loosening, a special nut such as lock nut, spring washer or self-locking nut should be used.

## Caution in use

- Never wash bearing with organic solvent and/or white kerosene, which have the ability to remove fat.
- To ensure normal rotation of the bearing, apply a load of 1% or more of the dynamic load rating at use.
- The operating temperature range is -15 to +80°C. For continuous operation, the recommended operating temperature is +60°C or less.
- When the lubrication is not enough between the outer ring and the mating track surface, seizure or wear may be occurred depending on the operating conditions. In particular, care must be taken for lubricating condition and the roughness of contacting surface in case of high-speed cam mechanisms use.



Stud dia. mm	Identification number	Mass (Reference) g	Boundary dimensions mm									
			D	C	d <sub>1</sub>	G	G <sub>1</sub>	B max	B <sub>1</sub> max	B <sub>2</sub>	B <sub>3</sub>	
6	CF 6 WBUUR/SG	18.5	16	11	6	M 6 × 1	8	12.2	28.2	16	—	
8	CF 8 WBUUR/SG	28.5	19	11	8	M 8 × 1.25	10	12.2	32.2	20	—	
10	CF 10 WBUUR/SG	45	22	12	10	M10 × 1.25	12	13.2	36.2	23	—	
	CF 10-1 WBUUR/SG	60	26	12	10	M10 × 1.25	12	13.2	36.2	23	—	
12	CF 12 WBUUR/SG	95	30	14	12	M12 × 1.5	13	15.2	40.2	25	6	
	CF 12-1 WBUUR/SG	105	32	14	12	M12 × 1.5	13	15.2	40.2	25	6	
16	CF 16 WBUUR/SG	170	35	18	16	M16 × 1.5	17	19.6	52.1	32.5	8	
18	CF 18 WBUUR/SG	250	40	20	18	M18 × 1.5	19	21.6	58.1	36.5	8	
20	CF 20 WBUUR/SG	460	52	24	20	M20 × 1.5	21	25.6	66.1	40.5	9	
	CF 20-1 WBUUR/SG	385	47	24	20	M20 × 1.5	21	25.6	66.1	40.5	9	

Note (1): Values in the table are applicable when the hardness of the mating track surface is 40HRC. When the hardness of the mating track surface differs from 40HRC, the track capacity is obtained by multiplying track capacity factor shown in Table 8.  
 Remark: Models with a stud diameter  $d_1$  of 10mm or less has no oil hole. The others are provided with one oil hole each on the outside surface and end surface of the stud.

Table 8 Track capacity factor

Hardness HRC	Tensile strength N/mm <sup>2</sup>	Track capacity factor
20	760	0.22
25	840	0.31
30	950	0.45
35	1 080	0.65
38	1 180	0.85
40	1 250	1.00
42	1 340	1.23
44	1 435	1.52
46	1 530	1.85
48	1 635	2.27
50	1 760	2.80
52	1 880	3.46
54	2 015	4.21
56	2 150	5.13
58	2 290	6.26

C <sub>1</sub>	g <sub>2</sub>	H	Mounting dimension f Min. mm	Maximum tightening torque N·m	Basic dynamic load rating	Basic static load rating	Maximum allowable load N	Track capacity (1) N
					C N	C <sub>0</sub> N		
0.6	—	3	11	2.7	3 660	3 650	1 950	1 040
0.6	—	4	13	6.5	4 250	4 740	4 620	1 330
0.6	—	4	16	13.8	5 430	6 890	6 890	1 610
0.6	—	4	16	13.8	5 430	6 890	6 890	2 030
0.6	3	6	21	21.9	7 910	9 790	9 790	2 470
0.6	3	6	21	21.9	7 910	9 790	9 790	2 710
0.8	3	6	26	58.5	12 000	18 300	18 300	3 060
0.8	3	8	29	86.2	14 800	25 200	25 200	3 660
0.8	4	8	34	119	20 700	34 600	34 600	5 190
0.8	4	8	34	119	20 700	34 600	34 600	4 530

Example of identification number

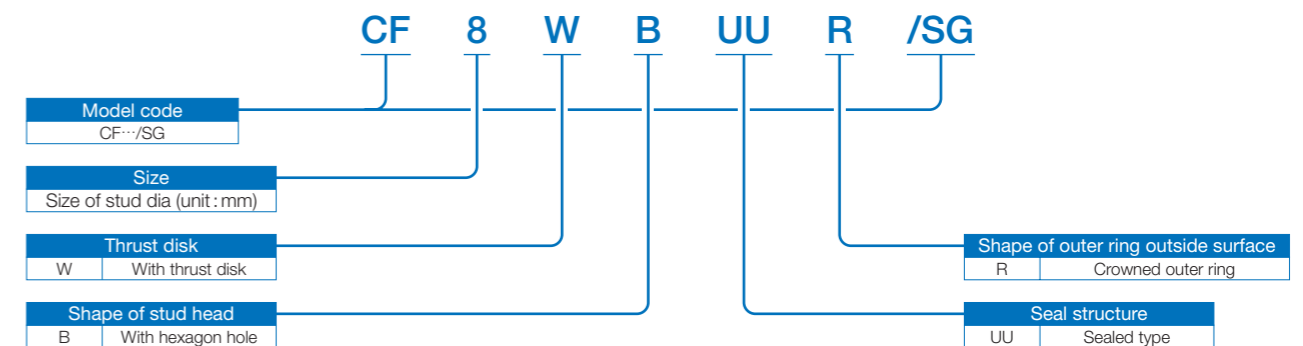

## Identification number

• Example

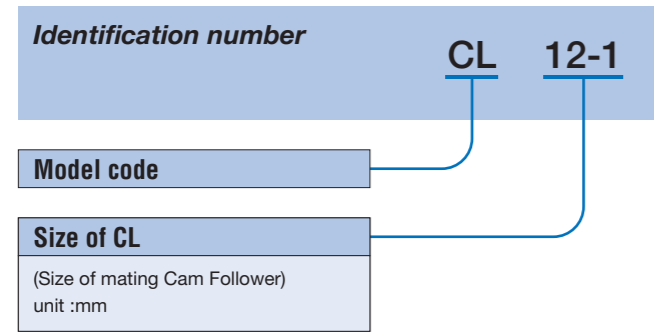

## Mounting

- Set the C-Lube Unit perpendicularly to the center axis of Cam Follower and fix together with Cam Follower by tightening nut.

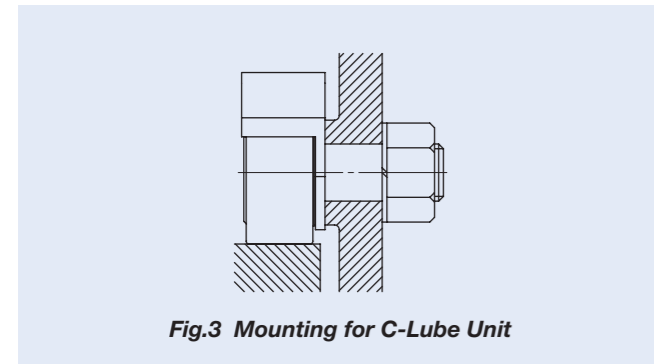

- Position of C-Lube Unit is adjustable. C-Lube Unit must be positioned avoiding loading direction.

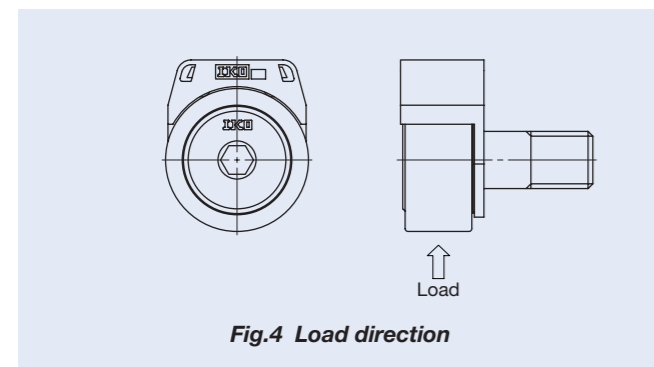

- When tightening the nut, the tightening torque should not exceed the value maximum tightening torque on dimension table. In case loosening of the nut is predicted due to vibration, using lock nut, spring washer and other special washer are recommended.

## Caution in use

- Maximum allowable static load**  
The maximum allowable load on IJKO Cam Follower with C-Lube Unit is, in some cases, limited by the bending strength and shear strength of the C-Lube Unit instead of the load rating of needle bearing part. In order to safety operation, actual load should be less than 80% or lower against the maximum allowable static load.

- Operation check**  
After assembling C-Lube Unit and Cam Followers in the machine, please confirm that C-Lube unit provides oil correctly to the track surface before actual operation.

- Minimum rotational angle**  
Lubricating oil is supplied to the whole external diameter surface of the outer ring. Accordingly, use the product in a condition in which the outer ring makes one or more turns.

- Allowable rotation speed**  
The rotation speed of IJKO Cam Follower with C-Lube Unit should not exceeded  $d_1 n = 10,000$  for reference.

$$d_1 n = d_1 \times n$$

$d_1$ : Stud diameter of Cam Follower, mm  
 $n$ : Rotational speed, rpm

- Operating temperature**  
Allowable operating temperature range of IJKO Cam Follower with C-Lube Unit is -15 to 80°C.

- Do not use in the environment where contamination of liquid and/or harmful foreign matters are expected.

- Do not wash with organic solvent and/or white kerosene, which have the ability of removing fat nor leave them in contact with the above agents.

- To ensure normal rotation of the Cam Follower, apply a load of 1% or over of the dynamic load rating at use.

- Replace with new C-Lube Unit when inside oil finishes completely. Re-lubrication is not possible.

- Do not apply a load onto the C-Lube Unit directly.

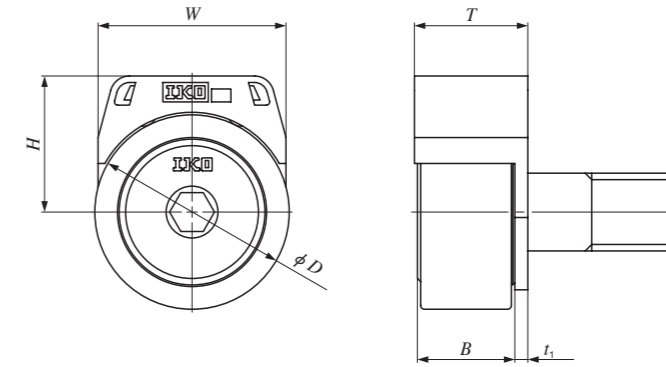

Model number	Boundary dimensions mm				Applicable Cam Followers		
	W	H	T	t <sub>1</sub>	Model number (1)	Boundary dimensions mm	
						D	B <sub>max</sub>
CL 6	15.4	12.6	14	1.5	CF 6 WB	16	12.2
CL 8	18.4	14.2	14	1.5	CF 8 WB	19	12.2
CL 10	21	17	15.5	2	CF 10 WB	22	13.2
CL 10-1	21	19.2	15.5	2	CF 10-1 WB	26	13.2
CL 12	29	21	17.5	2	CF 12 WB	30	15.2
CL 12-1	29	22	17.5	2	CF 12-1 WB	32	15.2

Note (1): Only representative models are shown in the table, and also applicable to the same size of standard type, with thrust washer type, centralized lubrication type, C-Lube maintenance free type and heavy duty type. Combine with C-Lube Cam Follower is strongly recommended for full maintenance free.  
(2): Actual load should not exceed these values.



## The invention in gratitude for rich global environment

# Maintenance free for 20,000km or 5 years

**IKO Maintenance Free & Interchangeable**

CAT-57149

## C-Lube Linear Way

ML ME MH MUL

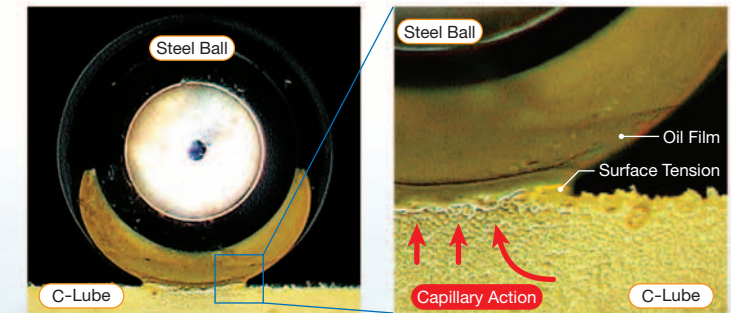
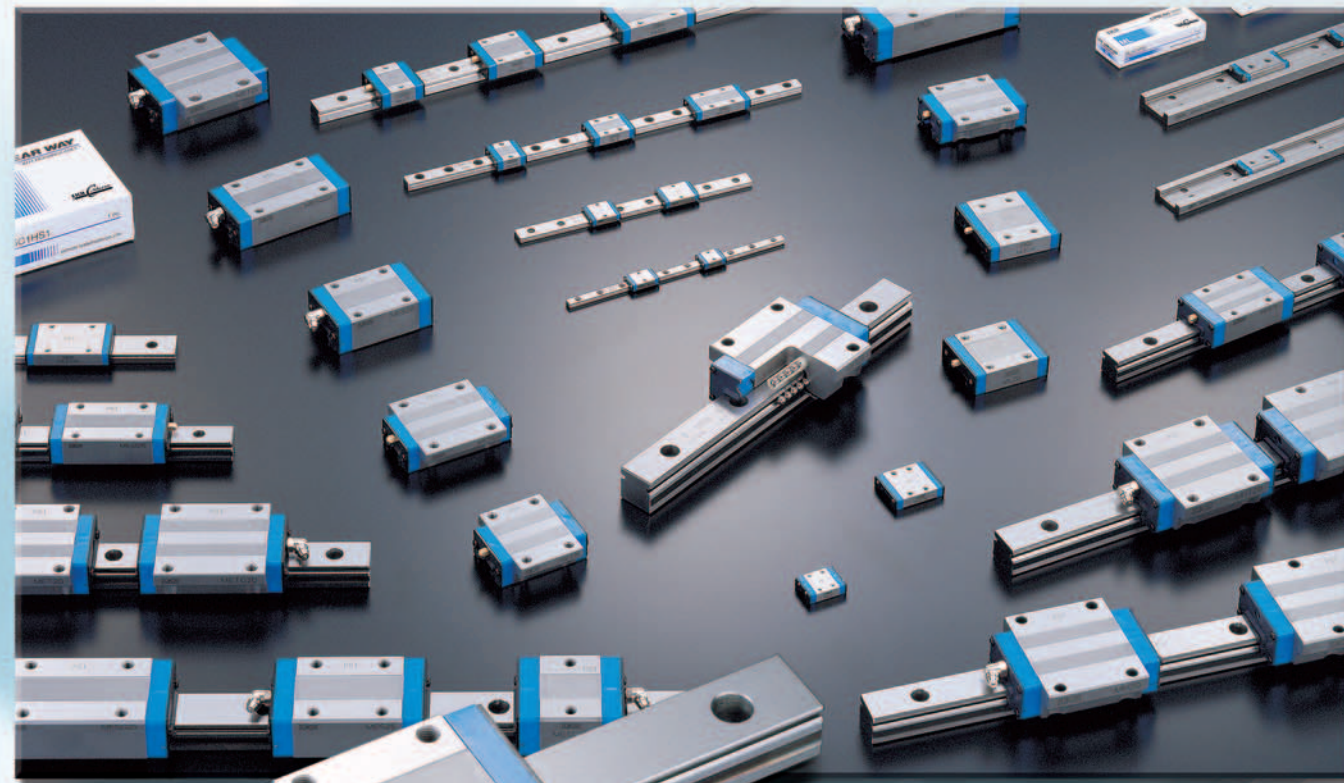

The Capillary system that IKO has developed is a new method of lubrication. The Lube-body is formed by sintering fine resin powder to act as reservoir and the open pores are impregnated with a large amount of lubrication oil. The capillary action deposits the appropriate amount of lubrication on the rolling elements to protect the raceways for long periods.

**Interchangeable series is available.**

C-Lube slide units can be supplied by themselves not with rails, and can be matched, replaced and added freely to the interchangeable track rail. This feature is useful in machine design, facilitating standardization of product specification and quick changes of specification.

### Maintenance Free

Efficiency of lubrication is maintained for a long term allowing to reduce the cost of lubrication management and control.

### Ecology

As C-Lube technology minimizes the amount of lubricant required that contributes to the global environment protection.

### Compact

Unlike attached-on external lubrication parts, there is no increase in carriage length.  
No loss of available stroke length when replacing standard units.

### Smooth

Light and smooth running is achieved by the improvement of internal design. C-Lube is designed not to have direct contact with the track rail allowing very smooth operation.

### Miniature type ML series



### Compact ME series



### High load capacity MH series



### U-shaped track rail MUL series



# World Network of **IKO**



## **NIPPON THOMPSON CO., LTD.**

Head office : 19-19 Takanawa 2-chome Minato-ku  
Tokyo 108-8586, Japan  
Phone : +81 (0)3-3448-5850  
Fax : +81 (0)3-3447-7637  
E-mail : ntt@ikonet.co.jp  
URL : <http://www.ikont.co.jp/eg/>  
Plant : Gifu, Kamakura

## **NIPPON THOMPSON CO., LTD.**

**ASEAN REPRESENTATIVE OFFICE**  
Level 8, #1 Silom Road, Silom  
Bangrak, Bangkok  
Thailand 10500  
Phone: +66 (0)-2-231-8278  
Fax: +66 (0)-2-231-8121  
E-mail: ntar@ikonet.co.jp

## **IKO-THOMPSON (SHANGHAI) LTD.**

Unit G, 23<sup>rd</sup> Floor, Zhao Feng World Trade Building  
No.369, Jiang Su Road  
Changning District, Shanghai 200050  
People's Republic of China  
Phone: +86 (0)21-5237-9100  
Fax: +86 (0)21-5237-9095  
E-mail: ntc@ikonet.co.jp

## **IKO INTERNATIONAL, INC.**

<http://www.ikont.com/>

### **East coast**

91 Walsh Drive  
Parsippany, NJ 07054  
U.S.A.  
Phone: +1 973-402-0254  
Toll Free: 1-800-922-0337  
Fax: +1 973-402-0441  
E-mail: eco@ikonet.co.jp

### **Midwest**

500 East Thorndale Avenue  
Wood Dale, IL 60191  
U.S.A.  
Phone: +1 630-766-6464  
Toll Free: 1-800-323-6694  
Fax: +1 630-766-6869  
E-mail: mwo@ikonet.co.jp

### **West coast**

20170 South Western Avenue  
Torrance, CA 90501  
U.S.A.  
Phone: +1 310-609-3988  
Toll Free: 1-800-252-3665  
Fax: +1 310-609-3916  
E-mail: wco@ikonet.co.jp

### **Southeast**

2150 Boggs Road, Suite 100  
Duluth, GA 30096  
U.S.A.  
Phone: +1 770-418-1904  
Toll Free: 1-800-874-6445  
Fax: +1 770-418-9403  
E-mail: seo@ikonet.co.jp

### **Southwest**

8105 N. Beltline Road  
Suite 130, Irving, TX 75063  
U.S.A.  
Phone: +1 972-929-1515  
Toll Free: 1-800-295-7886  
Fax: +1 972-915-0060  
E-mail: swo@ikonet.co.jp

## **NIPPON THOMPSON EUROPE B.V.**

<http://www.ikont.eu/>

### **The Netherlands**

Sheffieldstraat 35-39  
3047 AN Rotterdam  
The Netherlands  
Phone: +31 (0)10-4626868  
Fax: +31 (0)10-4626099  
E-mail: nte@ikonet.co.jp

### **Germany**

Mündelheimer Weg 56  
40472 Düsseldorf  
Germany  
Phone: +49 (0)211-414061  
Fax: +49 (0)211-427693  
E-mail: ntd@ikonet.co.jp

Im Gewerbepark D 30  
93059 Regensburg  
Germany  
Phone: +49 (0)941-206070  
Fax: +49 (0)941-2060719  
E-mail: ntdr@iko-nt.de

Gruben Str.95c  
66540 Neunkirchen  
Germany  
Phone: +49 (0)6821-999-860  
Fax: +49 (0)6821-999-8626  
E-mail: ntdn@iko-nt.de

### **UK**

2 Vincent Avenue, Crownhill  
Milton Keynes Bucks MK8 0AB  
United Kingdom  
Phone: +44 (0)1908-566144  
Fax: +44 (0)1908-565458  
E-mail: sales@iko.co.uk

### **Spain**

Autovia Madrid-Barcelona, Km. 43,700  
Polig. Ind. AIDA, A-8, Ofic. 2, 1<sup>a</sup>  
19200-Azuqueca de Henares  
Guadalajara, Spain  
Phone: +34 949-263390  
Fax: +34 949-263113  
E-mail: nts@ikonet.co.jp

### **France**

Roissypole Le Dôme  
2 rue de La Haye  
BP 15950 Tremblay en France  
95733 Roissy C. D. G. Cedex  
France  
Phone: +33 (0)1-48165739  
Fax: +33 (0)1-48165746  
E-mail: ntf@ikonet.co.jp

Recognizing that conservation of the global environment is the top-priority challenge for the world's population, **IKO** will conduct its activities with consideration of the environment as a corporate social responsibility, reduce its negative impact on the environment, and help foster a rich global environment.

**ISO 9001 & 14001 Quality system  
registration certificate**

